



CHRIST CHURCH GRAMMAR SCHOOL

**YEAR 11**

**PHYSICS ATAR**

**MID YEAR EXAMINATION 2018**

Stick Label Here

1			
2			
3			
Total		/ 120 =	%

### Time allowed for this paper

Reading time before commencing work: ten minutes

Working time for paper: two hours

### Materials required/recommended for this paper

#### *To be provided by the supervisor*

This Question/Answer Booklet

Formulae and Data Booklet

#### *To be provided by the candidate*

Standard items: pens (blue/black preferred), pencils (including coloured), sharpener, eraser, correction tape/fluid, ruler, highlighters

Special items: non-programmable calculators satisfying the conditions set by the SCSA for this course, drawing templates, drawing compass and a protractor

### Important note to candidates

No other items may be taken into the examination room. It is **your** responsibility to ensure that you do not have any unauthorised notes or other items of a non-personal nature in the examination room. If you have any un-authorized material with you, hand it to the supervisor **before** reading any further.

## Structure of this paper

Section	Number of questions available	Number of questions to be answered	Suggested working time (minutes)	Marks available	Percentage of exam
Section One: Short Answers	7	7	40	40	33 %
Section Two: Problem-Solving	4	4	60	60	50 %
Section Three: Comprehension	1	1	20	20	17 %
<b>Total</b>					<b>100</b>

## Instructions to candidates

1. Write your answers in this Question/Answer Booklet
2. When calculating numerical answers, show your working or reasoning clearly. Give final answers to three significant figures and include appropriate units where applicable.
3. You must be careful to confine your responses to the specific questions asked and to follow any instructions that are specific to a particular question.
4. The Formulae and Data booklet is **not** handed in with your Question/Answer Booklet.

**YEAR 11  
PHYSICS ATAR  
MID YEAR EXAMINATION 20**

**Section One: Short Response**

This section has **seven (7)** questions. Answer **all** questions. Write your answers in the space provided.

Suggested working time for this section is **40 minutes**.

**Question 1****(5 marks)**

Two substances with the same mass are made up of pure metals. One is pure gold and the other one is pure copper. The specific heat capacities of gold and copper are  $130.0 \text{ J kg}^{-1} \text{ K}^{-1}$  and  $390.0 \text{ J kg}^{-1} \text{ K}^{-1}$ , respectively.

- a) Explain what it is meant by the value  $130.0 \text{ J kg}^{-1} \text{ K}^{-1}$ .

(2 marks)

---

---

---

---

- b) With the same amount of energy being transferred to each metal, determine which metal will have the greatest change in temperature. Use appropriate formulae to support your answer.

(3 marks)

**Question 2****(6 marks)**

Complete the following nuclear equations and name the particles missing from the equation.

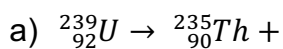

Name of the particle/s: \_\_\_\_\_

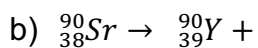

Name of the particle/s: \_\_\_\_\_

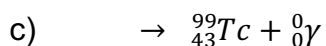

Name of the parent particle: \_\_\_\_\_

**Question 3****(6 marks)**

Neil wants to lower the temperature of his stainless-steel barbecue plate from 400.0 °C to 180.0 °C by spraying water directly onto the 25.0 kg plate. Calculate the mass of water, initially at 20.0 °C, required to cool the barbecue plate. Assume that all of the water completely evaporates to steam at 100 °C and that there is no energy lost to the environment. The specific heat capacity of the stainless-steel is 450.0 J kg<sup>-1</sup> K<sup>-1</sup>.

**Question 4****(6 marks)**

The initial activity of a radioactive source, an isotope of Radon, is 180.0 Bq. The half-life of Radon is 4.00 days.

- a) Calculate the activity of the Radon source after one day.

(3 marks)

- b) Plot the activity of the source against time from 0 to 12.0 days. Spare graph paper has been provided on page 10, should you require it.

(3 marks)

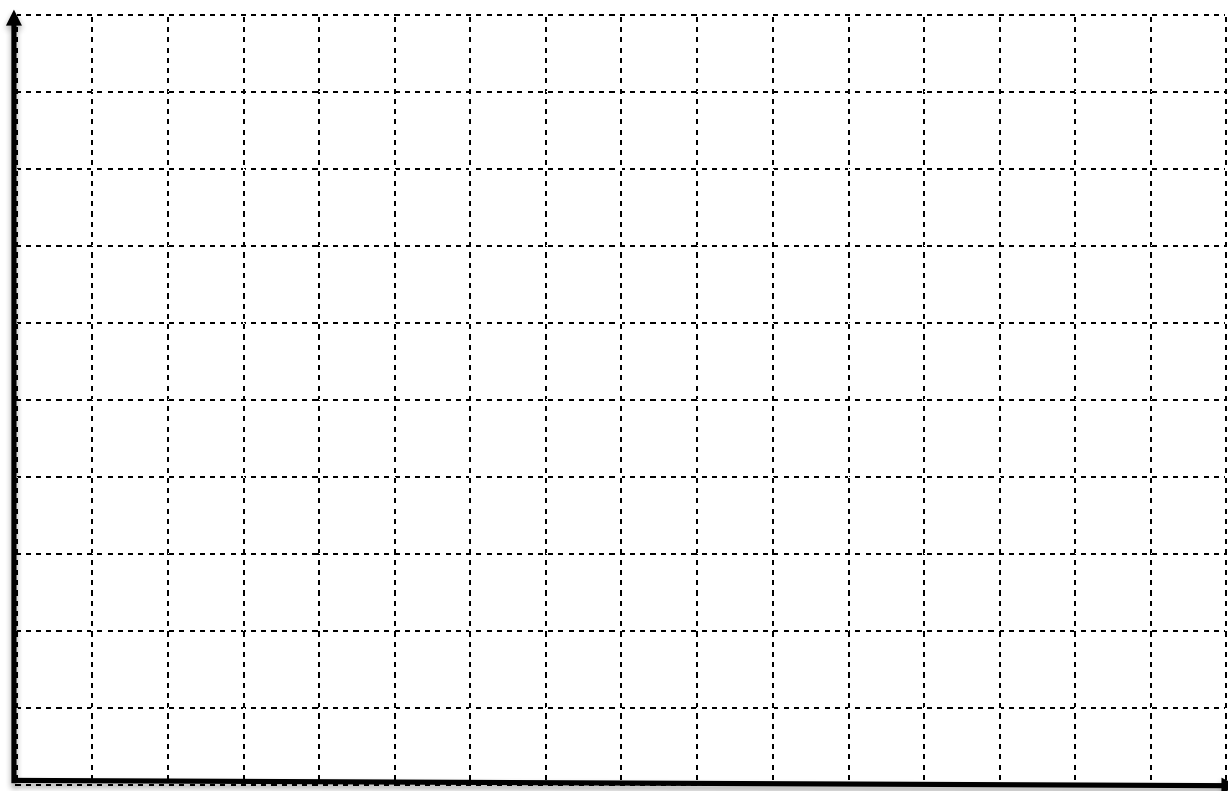

**Question 5**

**(6 marks)**

Roger is measuring the following shaded rectangle using the two rulers next to the rectangle, as shown below.

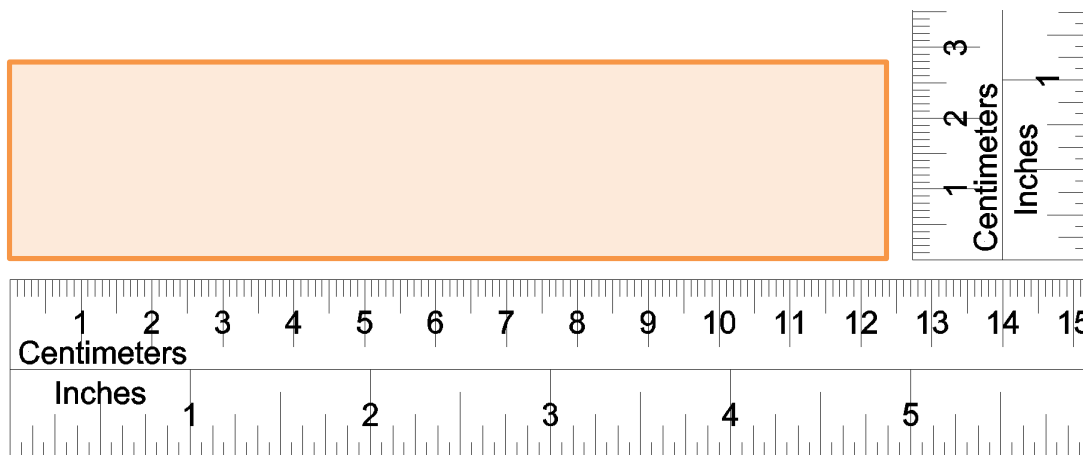

- a) Determine the width and length of the rectangle including absolute uncertainties. (2 marks)

Length: \_\_\_\_\_  $\pm$  \_\_\_\_\_

Width: \_\_\_\_\_  $\pm$  \_\_\_\_\_

- b) Calculate the absolute uncertainty of the area of the shaded rectangle. Show ALL working for full marks.

(4 marks)

**Question 6****(7 marks)**

A rating of a battery is “1.20 V, 1.60 A”. The battery is used for 1.00 hours.

a) Calculate the total charge passing through the battery in this time.

(2 marks)

b) Calculate the number of electrons that pass through the battery in this time.

(2 marks)

c) Calculate the total useful energy released by the battery, if the battery is 80.0% efficient.

(3 marks)



**Question 7**

**(4 marks)**

The diagram on the right shows a light bulb and a rheostat (a variable resistor) that are connected to a 12.0 V battery.

- a) On the diagram, draw an arrow showing the direction of electron current.

(1 mark)

- b) Explain, using relevant equations, how the rheostat could affect the brightness of the light bulb.

(2 marks)

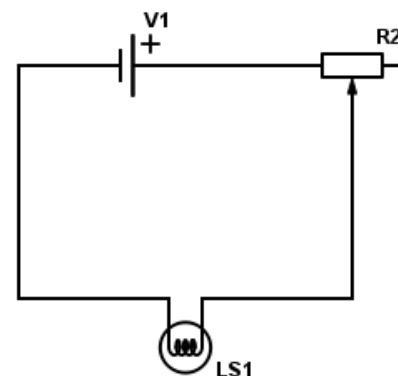

---



---



---



---



---



---

- c) If the rheostat is set to the maximum, the light bulb will be: (circle the answer)

(1 mark)

**The Brightest**

**The dimmest**

**No effect to the brightness**

Spare graph paper.

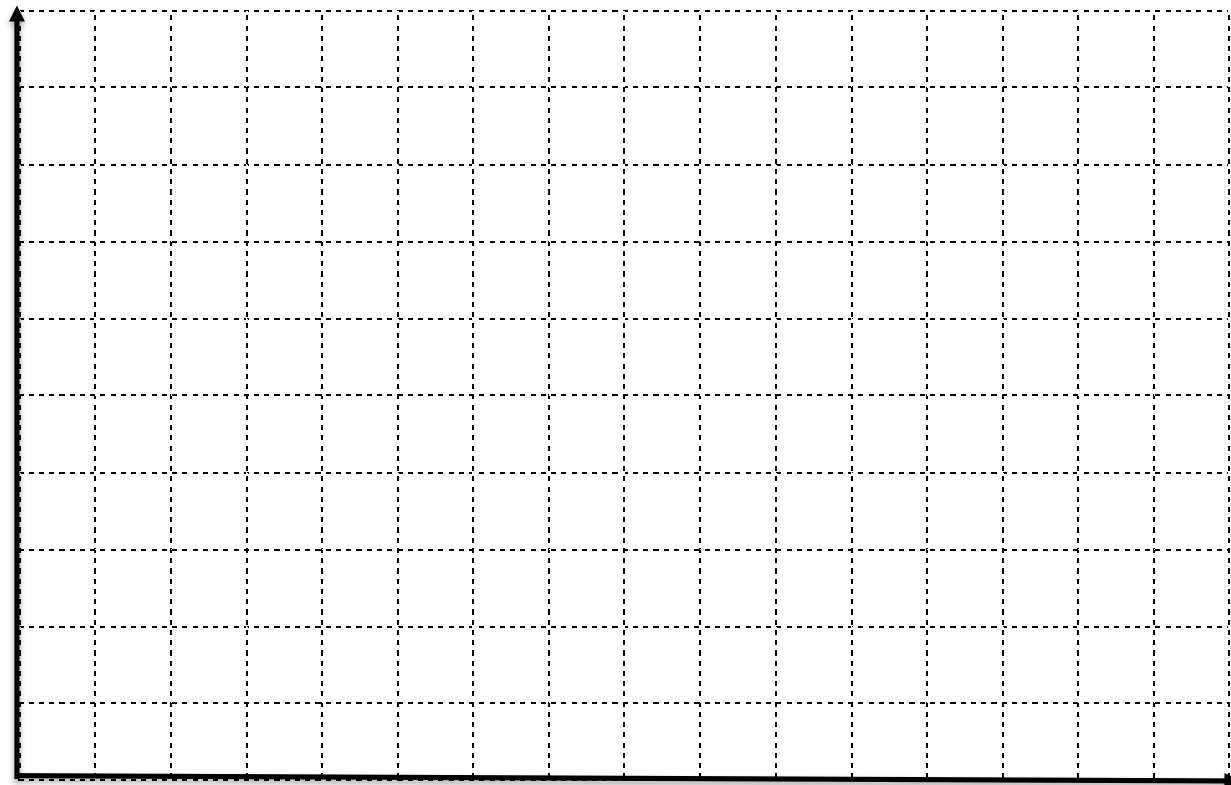

**This page has been left blank intentionally**

**This page has been left blank intentionally**

**YEAR 11  
PHYSICS ATAR  
MID YEAR EXAMINATION 2018**

**Section Two: Problem-Solving**

This section has **four (4)** questions. Answer **all** questions. Write your answers in the space provided.

Suggested working time for this section is **60 minutes**.

NAME: \_\_\_\_\_

TEACHER:            SFZ            JRM

**Question 8****(12 marks)**

In a fast breeder reactor, a neutron (1.00867 u), is captured and causes fission of Pu-239 (239.05216 u). One of the two fission fragments is Tc-104 (103.91145 u) and three neutrons are released. The atomic mass of the other fragment is 132.91525 u. Pu-239 is able to capture fast neutrons, whereas U-235 is only able to capture slow moving neutrons.

- a) State what component of a standard thermal nuclear reactor is not required in a fast breeder reactor.

(1 mark)

- b) Construct the decay equation as described in the text above.

(2 marks)

- c) Calculate how much energy, in MeV, is produced by this nuclear reaction. Show all working clearly.

(5 marks)

- d) If the average power consumption for Perth city is 600.0 MW daily, calculate the mass of Pu-239 (in kg) that could be used to provide Perth city with enough energy for 30.0 days.

(4 marks)

**Question 9**

**(16 marks)**

The follow graph shows the cooling curve of 1.00 kg of naphthalene from liquid to solid over 18.0 minutes. The naphthalene releases energy at a rate of 350.0 W as it cools from 90.0 °C.

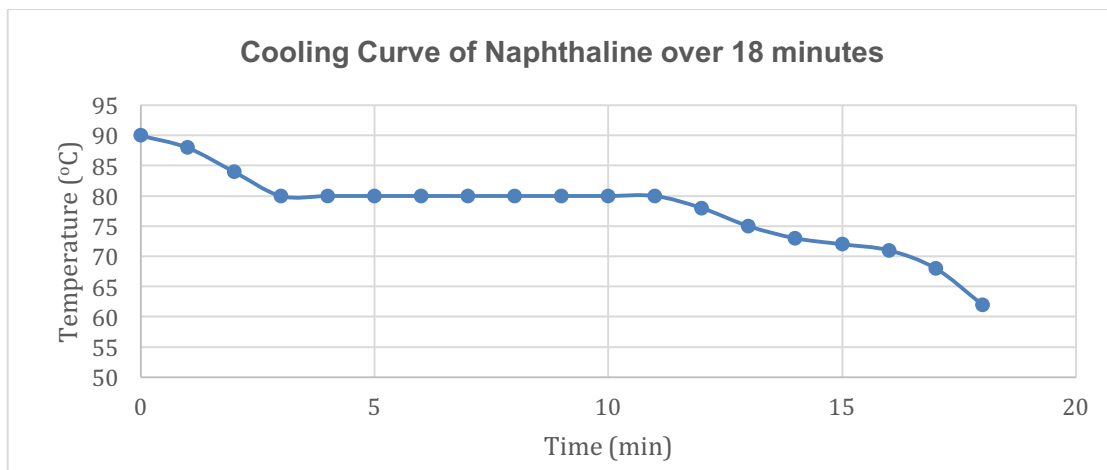

- a) On the graph above, label the time when the naphthalene is in its liquid state. (1 mark)
  
- b) Use the Kinetic Theory to explain why the curve stays flat between 3.00 minutes and 11.0 minutes. (3 marks)

---



---



---



---

A value for the latent heat of fusion can be found using the curve.

- c) Calculate the total energy released between 3.00 minutes and 11.0 minutes. (2 marks)



d) Hence, determine a value for the latent heat of fusion of naphthalene.

(3 marks)

e) Use the graph to **estimate** the specific heat capacity of the solid naphthalene.

(4 marks)

f) On the graph below, redraw new cooling curves if the mass of the naphthalene is doubled. Assume the rate of energy lost is the same as before and the initial temperature stays at 90.0 °C.

(3 marks)

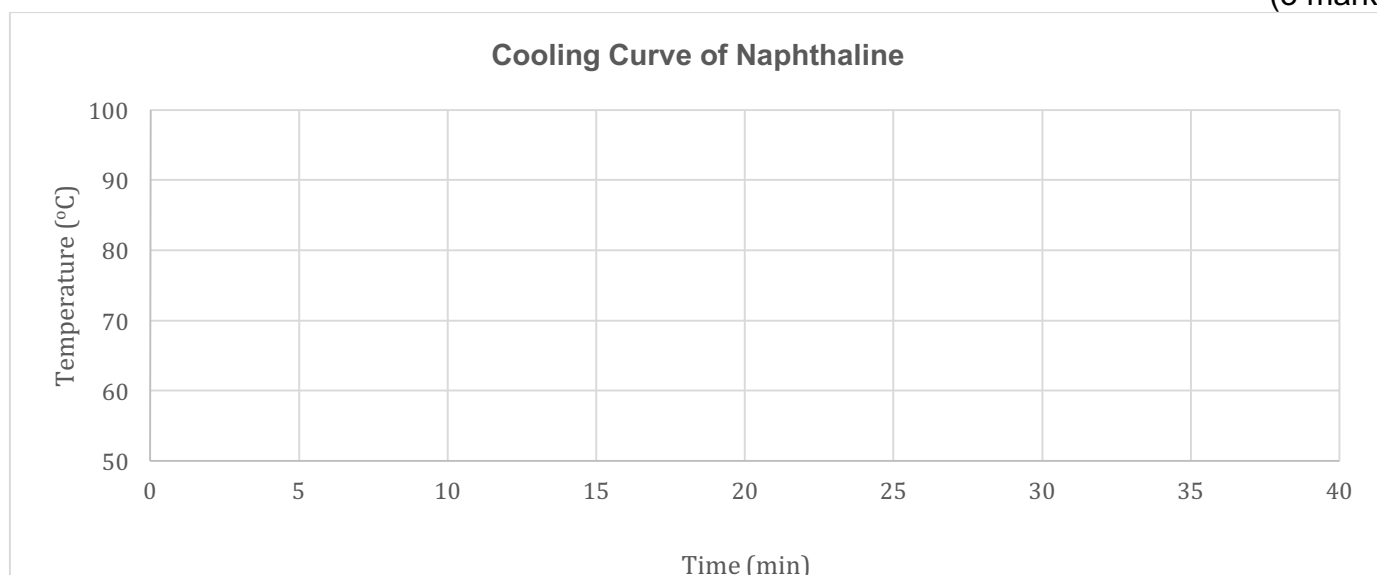

**Question 10**

**(14 marks)**

A quality-control officer tests a strand of nylon cord by subjecting it to various loads (force) and recording the subsequent extensions. The diagram of the setup is shown on the right. The original length of the nylon string is measured as 100.0 mm and the string is measured with a scale in mm increments.

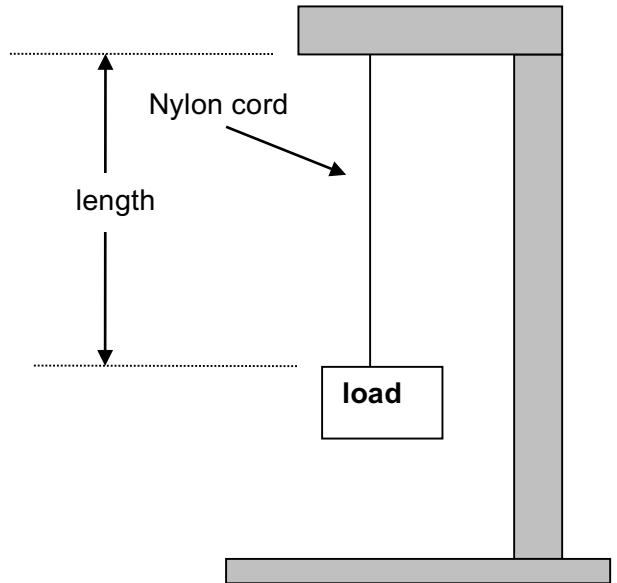

a) Complete the following: (2 marks)

Independent variable: \_\_\_\_\_

Dependent variable: \_\_\_\_\_

b) Complete the table. (1 mark)

<b>F (N)</b>	0	10	20	30	40	50
<b>L (mm)</b>	100.0	108.1	117.4	124.4	132.3	139.4
<b><math>\Delta X</math> (mm)</b>						

**F:** Load, in Newtons

**L:** Length, in millimetres

**$\Delta X$ :** Extension or change of length to 100.0 mm (initial length).

c) Calculate the absolute uncertainty for the **Extension of the nylon** string if the load is 20 N. (3 marks)

d) Plot the graph using  **$\Delta X$**  and **load** (See the next page).  
Spare graph paper has been provided on page 22, should you require it.

**(4 marks)**

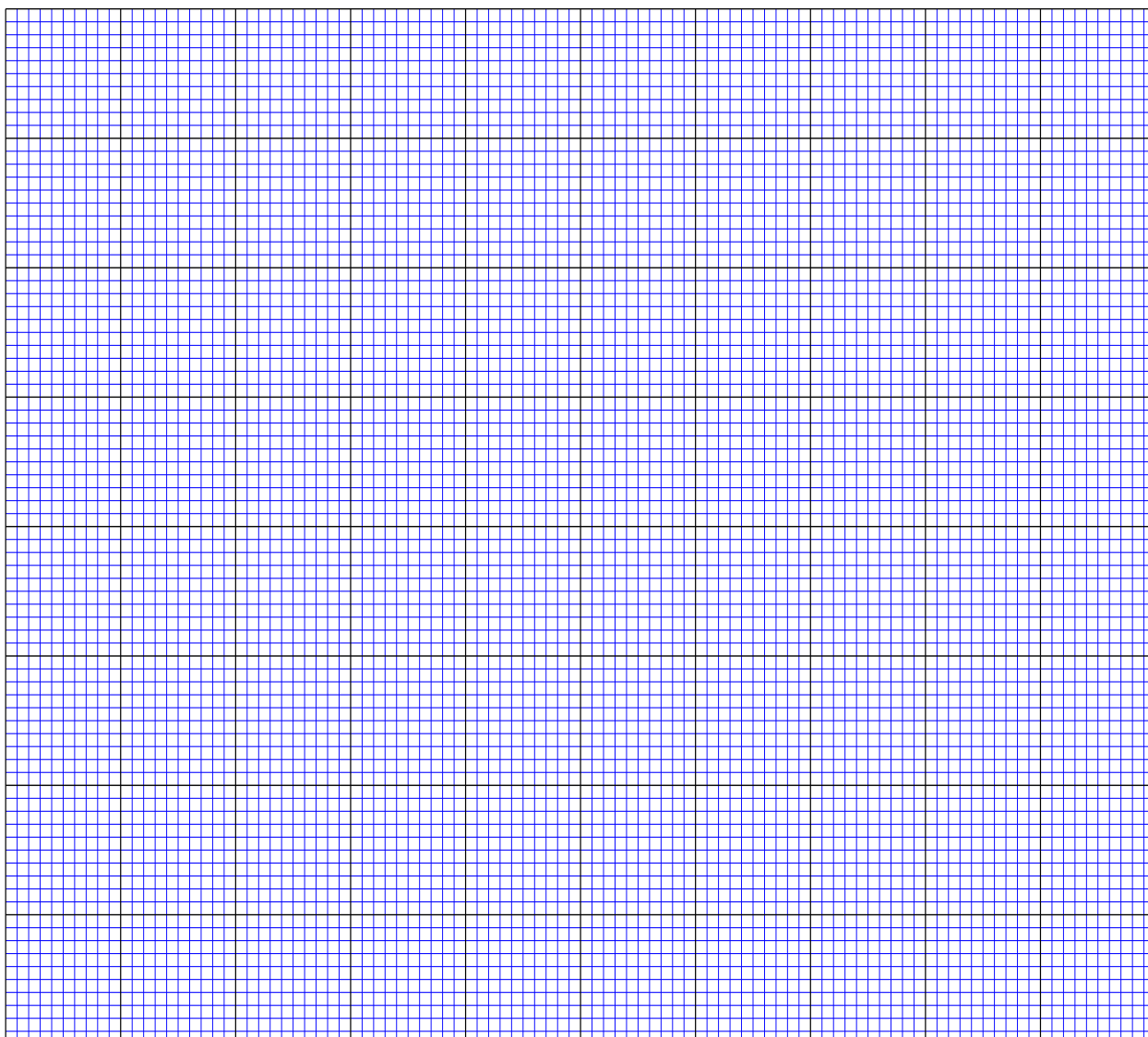

e) Calculate the gradient of the graph. Show all working out clearly.

(4 marks)

**Question 11**

**(18 marks)**

As shown below, six resistors are connected in a network to a 12.0 V battery (V1). The values of the resistors are also shown below:

- R1 = 10.0 Ω
- R2 = 12.0 Ω
- R3 = 4.00 Ω
- R4 = unknown
- R5 = 6.00 Ω
- R6 = 20.0 Ω

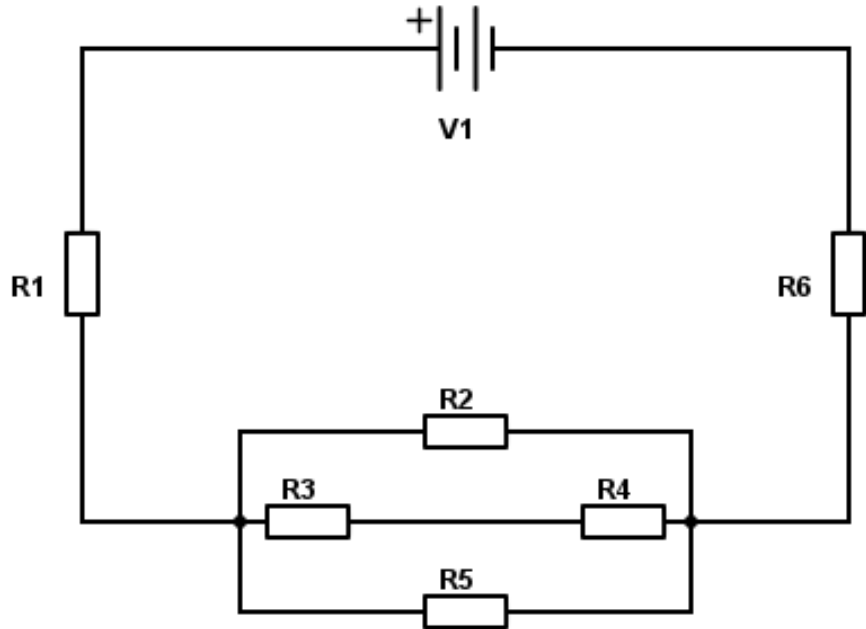

- a) On the diagram above, draw an arrow to show the direction of conventional current through resistor R1. (1 mark)
- b) On the diagram above, show how you would connect a voltmeter to measure the voltage of R2. (1 mark)
- c) Outline what the voltmeter in part b) is effectively measuring, in terms of the charge flowing through R2. (2 marks)

It is found that the circuit current measured in the main circuit is 0.371 A.

- d) Calculate the voltage across resistor R1 and R6. Show all working below. (2 marks)

e) Hence, calculate the voltage across R2.

(2 marks)

f) Show through calculation that the current flowing through R4 is 0.153 A.

(5 marks)

g) Hence, calculate the resistance of R4.

(3 marks)

h) If resistor R4 burns out, state whether the total current would increase or decrease. Explain your answer. No calculations are required.

(2 marks)

---

---

---

**End of Section Two**

Spare graph paper.

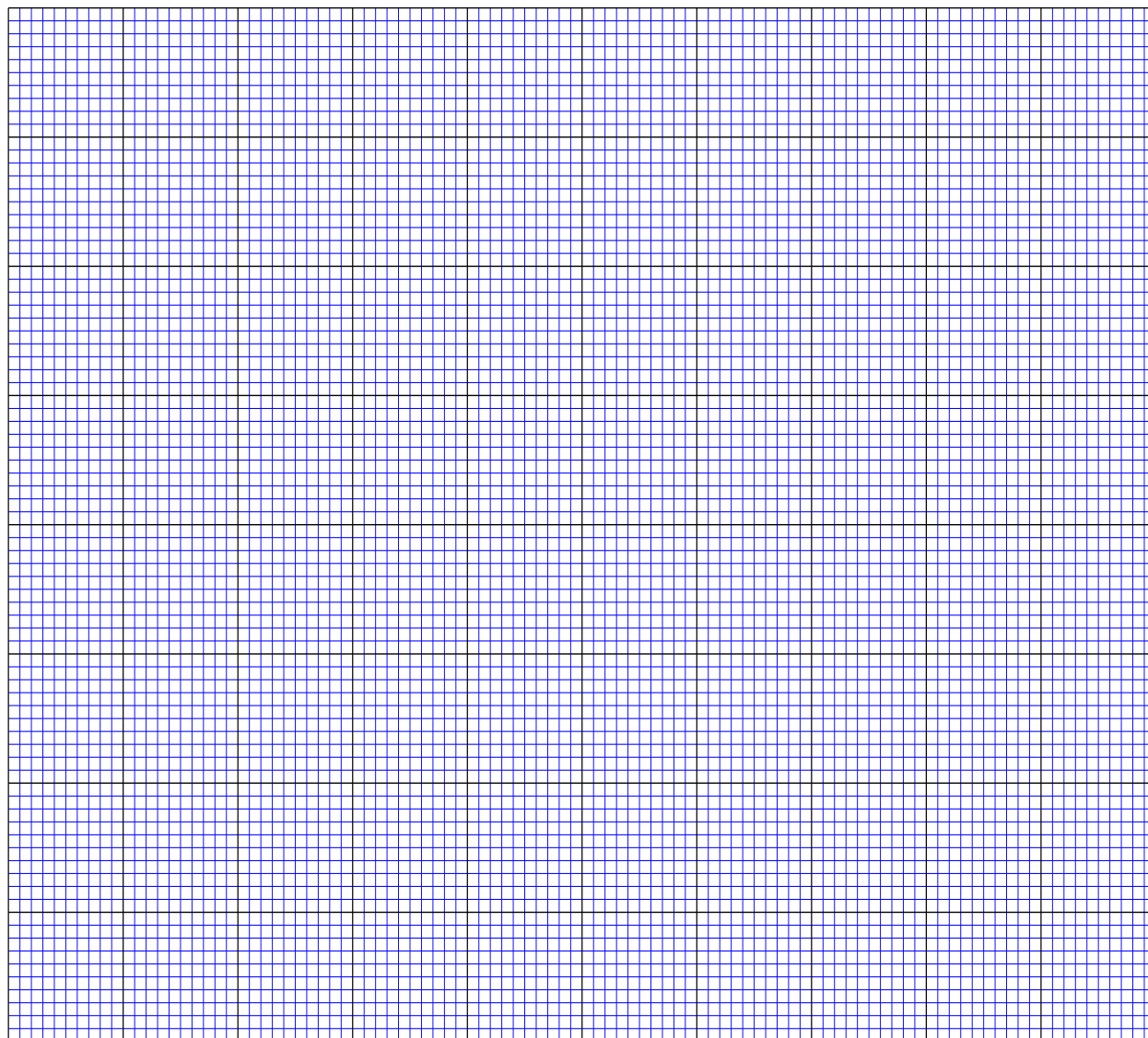

**This page has been left blank intentionally**

**This page has been left blank intentionally**



**YEAR 11  
PHYSICS ATAR  
MID YEAR EXAMINATION 20**

**Section Three: Comprehension**

This section has **one (1)** question. Write your answers in the space provided.

Suggested working time for this section is .

NAME: \_\_\_\_\_

TEACHER:            SFZ            JRM

**Question 1****(20 marks)**

*In 2015, a single salmon caught in Osoyoos Lake in British Columbia was found to contain very low levels of a radioactive isotope called caesium-134.*



Figure 1 Were salmon in Canada really contaminated with radioactive isotopes from the damaged nuclear power plant at Fukushima in Japan?

A news story has done the rounds on social media this year claiming that salmon in Canada had been found contaminated with radioactive isotopes from the damaged nuclear power plant at Fukushima in Japan. Is it true? And, if so, is there anything to worry about? The answer to the first question is “yes, sort of”, but the answer to the second is “definitely not”!

The story grew from the fact that, in 2015, a single salmon caught in Osoyoos Lake in British Columbia was found to contain very low levels of a radioactive isotope called caesium-134. The isotope is produced during nuclear fission – the process that drives both atomic power stations and atomic bombs. Because it has a half-life of 2.04 years, any caesium-134 that was released into the atmosphere by previous bomb tests or reactor disasters (such as Chernobyl) has long since decayed away. Therefore, any caesium-134 found in anything at the moment can only have come from Fukushima. So, yes, a radioactive nasty from Japan did end up in a fish in Canada. However, there is much more to the story than that.

First off, scientists have always predicted that radioactive stuff from the damaged reactor would spread around the world, through the oceans and the air. This is simply what happens. Between 1955 and 1963, for instance, there were a whole bunch of atmospheric nuclear bomb tests, which collectively pumped out a huge amount of an isotope called carbon-14. All over the world, people who were children during that time have higher-than-average levels of it in their muscle tissues.

In 2016, caesium-134 from Fukushima was detected in the waters off the coast of the north-western US state of Oregon for the first time. This did not surprise environmental scientists and oceanographers, who had long predicted its eventual arrival. The isotopes detected in the sea were at very low levels and didn't pose any threat to human health. The same goes for the single Canadian salmon. In fact, the radiation levels detected in the fish were actually lower than the levels found in most other fish around the globe. This is because, every day, every living thing absorbs radiation produced naturally by cosmic rays, some kinds of rocks and minerals, and even the air itself. It's called “background radiation” and it has been around since the Big Bang.

The suspect salmon wasn't eaten, because it was used for testing. But if it had been, would it have made the person who ate it ill? Not at all. The standard measurement for radiation in food is a unit called the becquerel. It is always expressed in terms of becquerels per kilogram. The Canadian salmon contained 0.7 becquerels per kilogram. The World Health Organisation's recommended safe maximum limit for radioisotopes in food is 1,000 becquerels per kilogram. So, should you ever be lucky enough to find yourself hooking a sockeye salmon in Osoyoos Lake, have no fear. Wrap it in foil with a few slices of lemon and some thyme, chuck it on the camp fire, and enjoy!

a) Explain why it is important to measure the level of radiation in fish.

(2 marks)

---

---

---

---

---

---

---

b) Fukushima Daiichi reactors exploded in 2011. Now the radiation “stuff” is said to be spread around the world due to water currents. Outline why the author does not believe this radiation to be harmful.

(2 marks)

---

---

---

---

c) According to the article, there are many sources of radiation which could affect our lives. Apart from the nuclear reactor plants, state two more.

(2 marks)

- d) Calculate the binding energy per nucleon of caesium-134. Express your answer in MeV.

Use the following data:

Mass of proton	=	1.00727 u
Mass of neutron	=	1.00867 u
Mass of Caesium-134	=	133.907 u

(4 marks)

- e) The caesium-134 undergoes alpha decay followed by a beta positive decay. Write down the two equations of this decay series.

(3 marks)

- f) A 6.00 kg salmon has eaten food that contains caesium-134 with a radiation level of  $4.00 \times 10^5$  Bq. **Estimate**, how long it will take for the salmon to be safe according to the World Health Organisation's recommended maximum limit.

(4 marks)

A 6.00 kg salmon receives a whole-body dose of beta radiation, absorbing  $3.67 \times 10^{-3}$  J of energy.

- g) Calculate the equivalent does of the salmon in this period.

(3 marks)

**Acknowledgements****Question 19**

Adapted from: Masterson, A. (2017). *Cosmos. Are Canadian fish being poisoned by radiation from Japan?*. Retrieve November 30, 2017, from <https://cosmosmagazine.com/chemistry/are-canadian-fish-being-poisoned-by-radiation-from-japan>

**This page has been left blank intentionally**

**This page has been left blank intentionally**

**This page has been left blank intentionally**